

# PACK INOLINE • HÊTRE • réf.809

## FIXATION LATÉRALE

GB side fastened posts • E postes fijación lateral • P postes de fixação lateral • IT pali di fissaggio laterale • NL paaltje bevestiging zijkant • D Seitenbefestigungspfosten • TU Yan montaj sonrası • PL po montażu boczno • RO partea mesaj montare • RU бокового крепления пост.

**BURGER.fr**

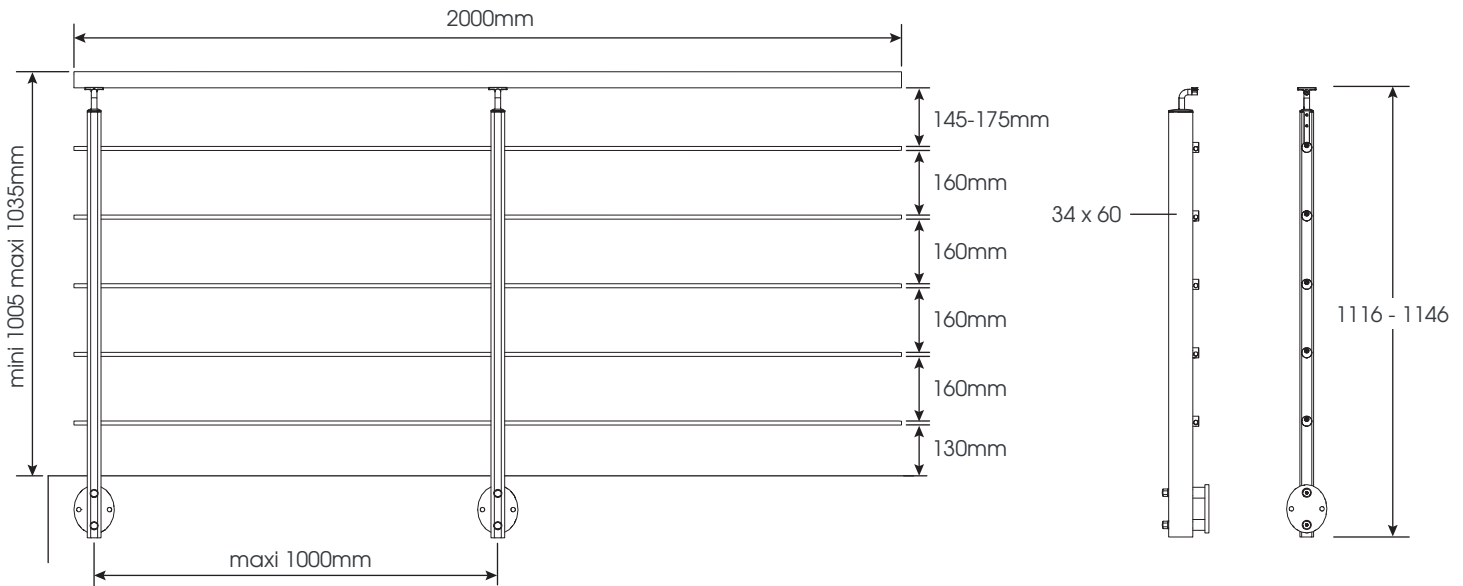

## COMPOSITION

GB Contents of pack • ES Composición • PT Composição • IT Co mposizione • NL Samenstelling • D Zusammensetzung des Bausatzes  
zestawu • RO Pieseale componente ale kitului • RU Состав набора

• TU kompozisyon • PL Zawartość

<b>1</b>	22023		34x60x1055mm	x2
<b>2</b>	22024		Ø40x2000mm	x1
<b>3</b>	70374		Ø10x2000mm	x5

<b>4</b>	72361		x2
<b>5</b>	72361		x2
<b>6</b>	70018		x2
<b>7</b>	72361		x10
<b>8</b>	70017		x4
<b>9</b>	70638		x5
<b>10</b>	70014		x1
<b>11</b>	70632		x10
<b>12</b>	MEM1		x2

<b>A</b>	72162		M10x110mm	x4
<b>B</b>	72361		Ø5x40mm	x10
<b>C</b>	72361		M6x20mm	x4
<b>D</b>	72411		Ø5x20mm	x4
<b>E</b>	72340		M10	x4
<b>F</b>	72163		M10	x4

# Montage du poteau

x2

GB post assembly • ES ensamblaje del poste • PT montagem do poste • IT assemblaggio del palo • NL assemblage paal  
 • D Zusammenbau des Pfostens • TU direk birleştirici-toplayıcı • PL montaż słupka • RO asamblarea stâlpului • RU Сборка опоры

Сборка

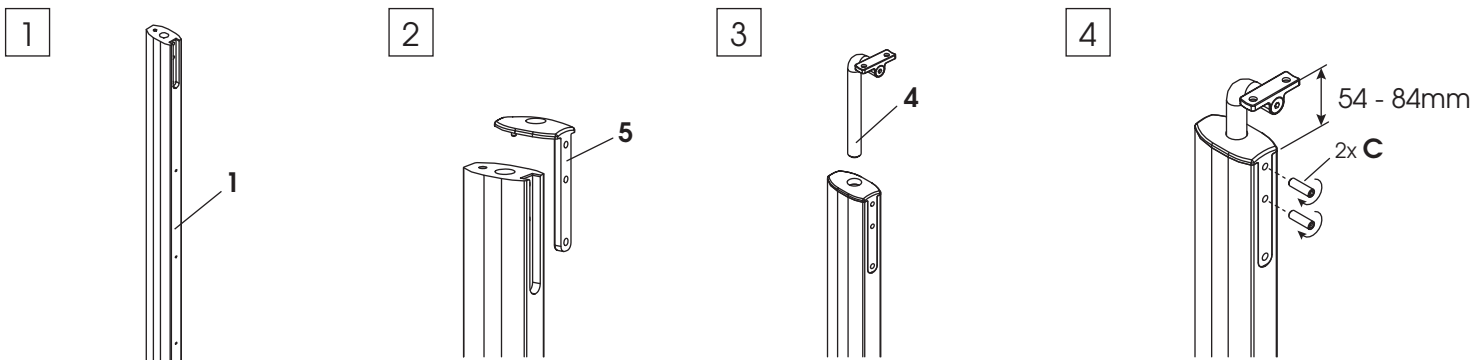

Ne pas serrer trop fort

GB • don't tighten too hard  
 ES • no apretar demasiado fuerte  
 PT • Não apertar muito forte  
 IT • non stringere troppo forte  
 NL • Niet te krachtig vastzetten  
 D • Nicht zu fest anziehen  
 TU • A şırı sıkmayın  
 PL • Nie przekręcaj  
 RO • Nu strângeți  
 RU • Не затягивайте

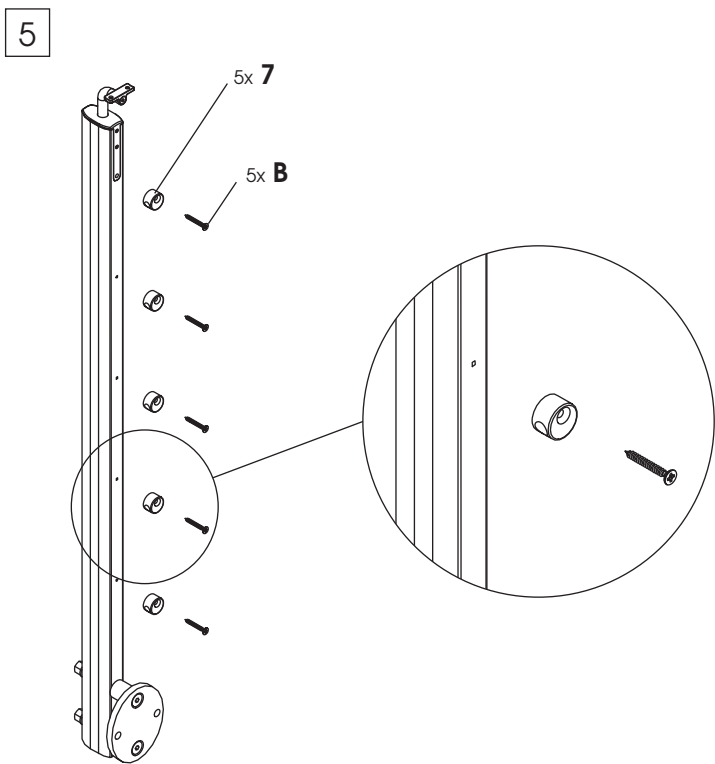
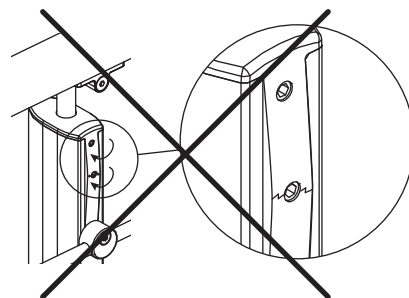

## montée d'escalier

GB • for crawling stairs  
 ES • para el rastreo escaleras  
 PT • para rastreamento de escadas  
 IT • per la scansione scale  
 NL • voor het crawlen trappen  
 D • für Treppenaufgang,  
 TU • merdiven basamakları için  
 PL • do schodów  
 RO • pentru urcarea scării  
 RU • для лестницы, несущие балки крепятся горизонтально.

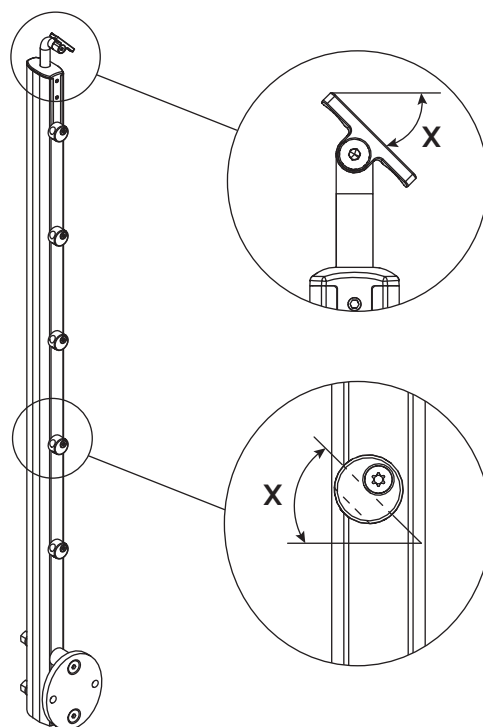
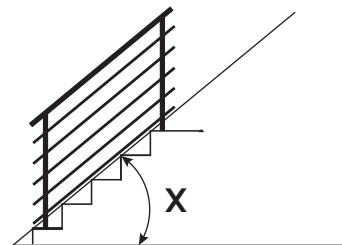

## Fixation au sol

•GB accessories postes fasteners • ES accesorios postes sujetadores • PT acessórios postes prendedores • IT Accessori pali fermi • NL accessoire paal bevestigingsmiddelen • D Zubehör Pfosten Verschlüsse • TU direkleri tutturma aksesuari • PL akcesoria słupki mocuj  
• RO Pieseale componente ale kitului • RU аксессуары столбы крепеж

ăce

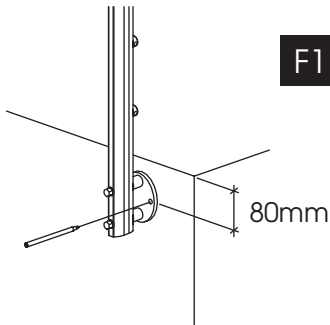

### F1 tirefonds pour sol bois

GB • Lag bolts for wood floors  
ES • Tirafondos para suelos de madera  
PT • Tira-fundo para pavimento em madeira  
IT • Tirafondi per pavimento in legno  
NL • Slotschroef voor houten vloer  
D • Sechskantschrauben für Holzboden  
TU • a ğaç zemin için civata  
PL • Wkr ęt do podłogi drewnianej  
RO • Őuruburi autofiletante pentru podea din lemn  
RU • Фундаментальные болты для деревянного пола

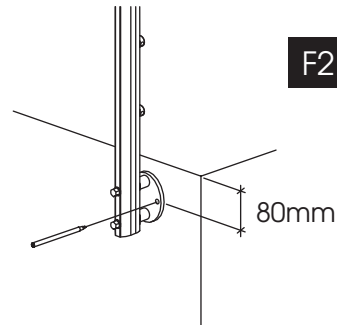

### F2 tirefonds pour sol béton

GB • Anchor bolts for concrete floors  
ES • Tacos para suelos de hormigón  
PT • Cavilhas para pavimento em betăo  
IT • Caviglie per pavimenti in cemento  
NL • Pluggen voor betonnen vloer  
D • Schwerlastanker für Betonboden  
TU • beton zemin için civata  
PL • Monta Ź por ęczy do ściany  
RO • Dibluri pentru podea din beton  
RU • Штыри для бетонного пола.

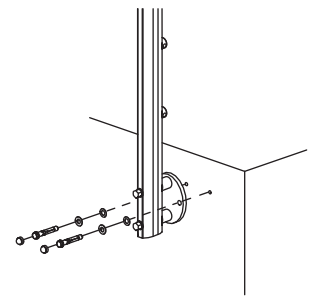
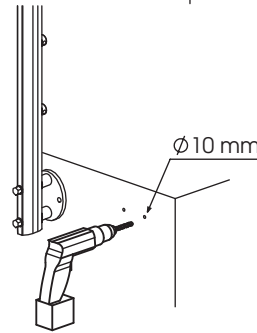
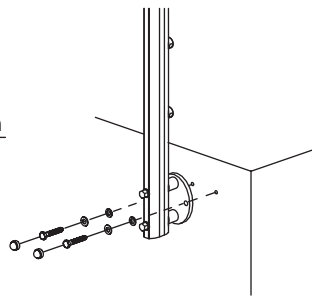
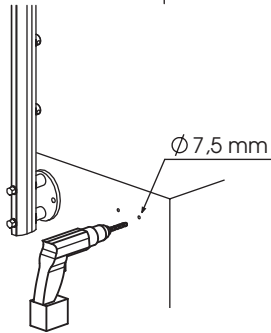

## Fixation des tubes

GB • Tube fastening  
ES • Fijaci3n para tubos  
PT • Fixa3ăo para tubos  
IT • Fissaggio per tubi  
NL • Bevestiging voor buizen  
D • Befestigung für Rohre  
TU • Borular için sabitleme  
PL • Zamocowanie przewod3w rurowych  
RO • Suport tuburi  
RU • Фиксатор для труб

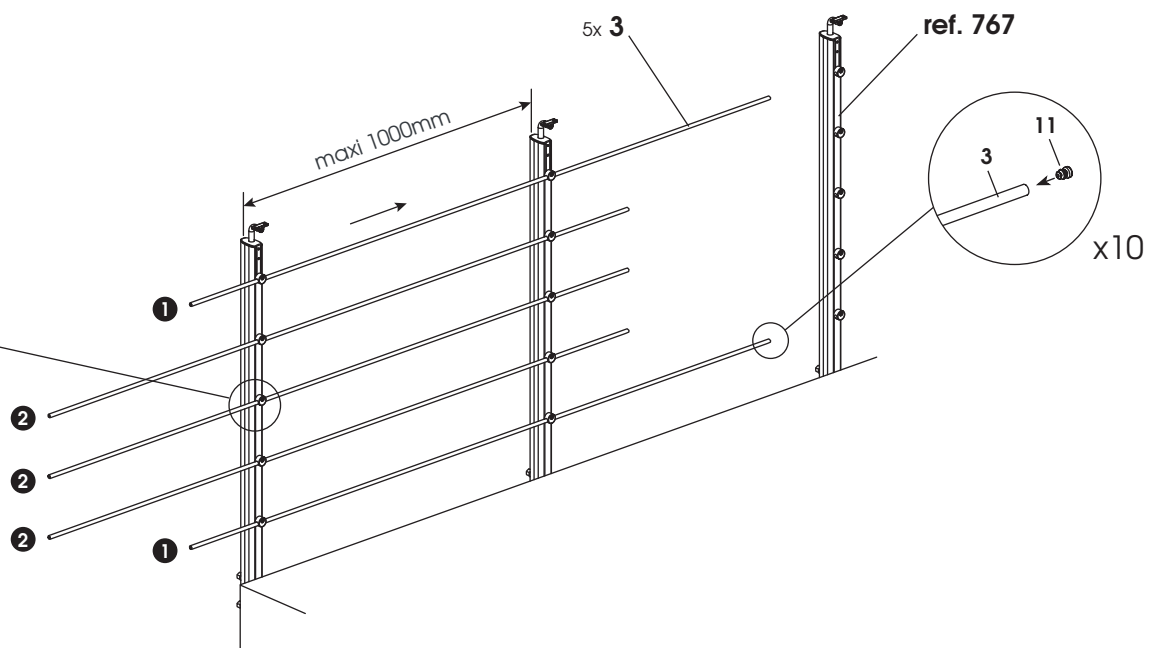
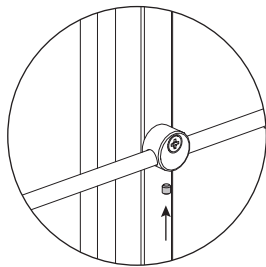

## Fixation de la main courante

GB • Fastening the handrail to the post  
ES • Fijaci3n de pasamanos a la postes  
PT • Fixa3ăo de corrimăo na postes  
IT • Fissaggio di ringhiera su pali  
NL • Bevestiging van leuning aan paal  
D • Befestigung für Handlauf an der Pfosten  
TU • dire ğe korkulukları tutturma  
PL • Zamocowania por ęczy do słupki  
RO • fixare pol balustrad ă  
RU • Крепление перил к опоры

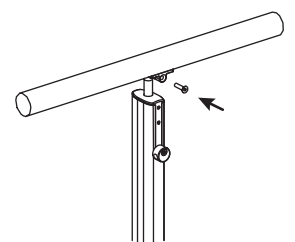
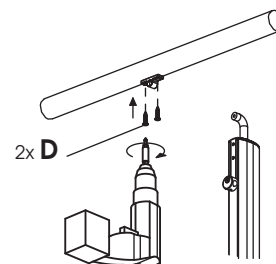
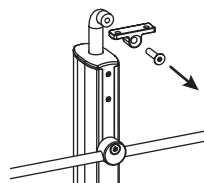
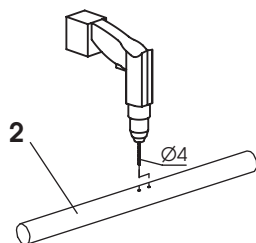
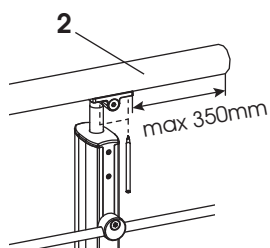
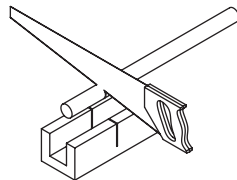

## Assemblage des tubes

x5

GB Assemblers for stainless steel tubes • ES montadores de tubos de acero inoxidable • PT montadores de tubos de aço inoxidável • IT assemblatori di tubi in acciaio inox • NL monteurs voor roestvrij stalen buizen • D Montagebetriebe für Edelstahlrohre • TU Birle ştirici Paslanmaz tüb • PL monterzy dla rur ze stali nierdzewnej • RO piese de asamblare inox • RU монтажные для труб из нержавеющей стали

tevi

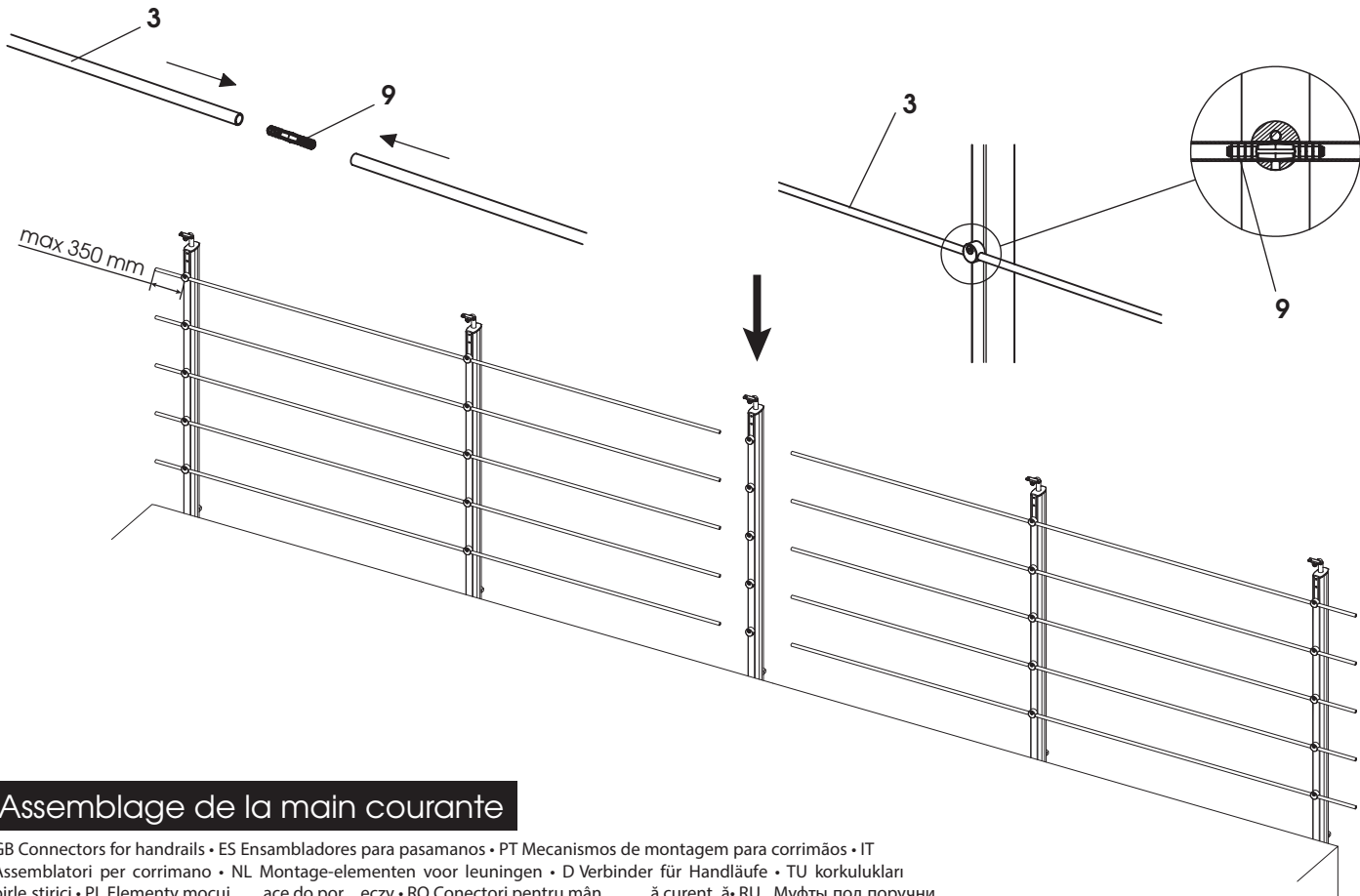

## Assemblage de la main courante

GB Connectors for handrails • ES Ensambladores para pasamanos • PT Mecanismos de montagem para corrimãos • IT Assemblatori per corrimano • NL Montage-elementen voor leuning • D Verbinder für Handläufe • TU korkulukları birle ştirici • PL Elementy mocuj ące do por ęczy • RO Conectori pentru mân ă curent ă • RU Муфты под поручни

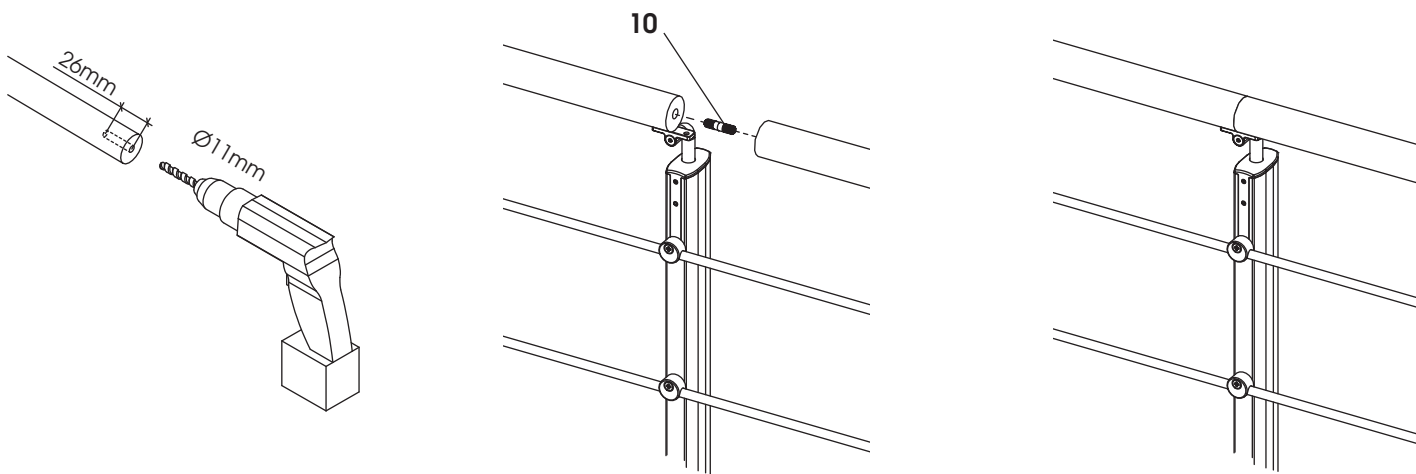

## Finition de la main courante

GB • Handrail end caps  
ES • Conteras de acabado de pasamanos  
PT • Tampões de extremidade de corrimão  
IT • Ghiera di finitura del corrimano  
NL • Dopstukken leuning  
D • Endkappe für Handlauf  
TU • Dökme alüminyum korkuluk biti yüksü ğü.  
PL • Końcówki por ęczy  
RO • Capace de finisare pentru mân ă curent ă  
RU • Наконечники для окончательной отделки поручней.

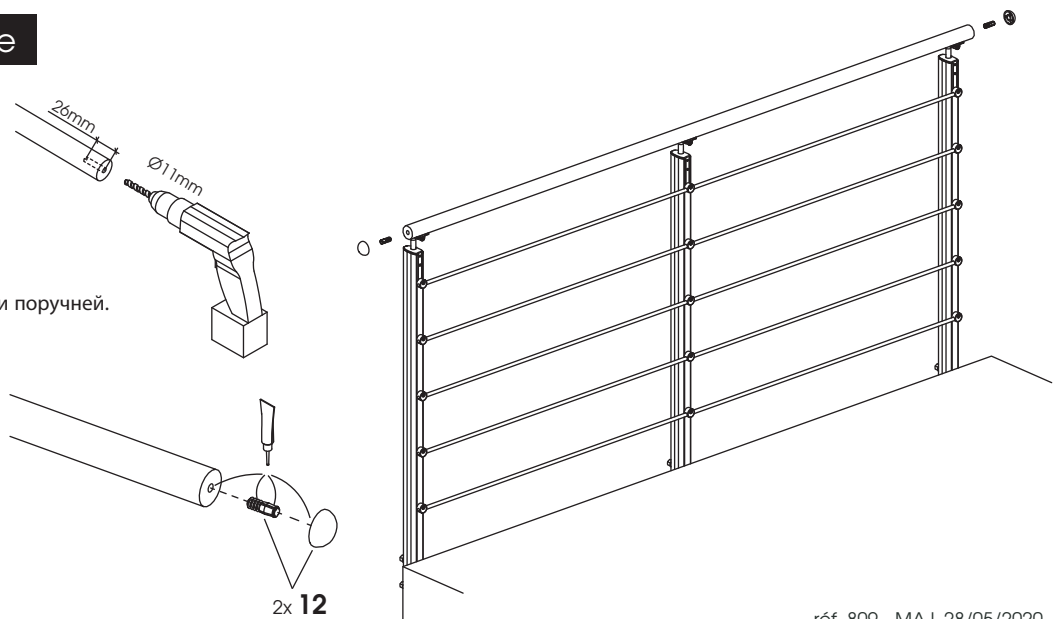

2x 12

# PACK INOLINE • HÊTRE • réf.808

**BURGER.fr**

## FIXATION PLAT

GB side fastened posts • E postes fijación lateral • P postes de fixação lateral • IT pali di fissaggio laterale • NL paaltje bevestiging zijkant • D Seitenbefestigungspfosten • TU Yan montaj sonrası • PL po montażu bocznego • RO partea mesaj montare • RU бокового крепления пост.

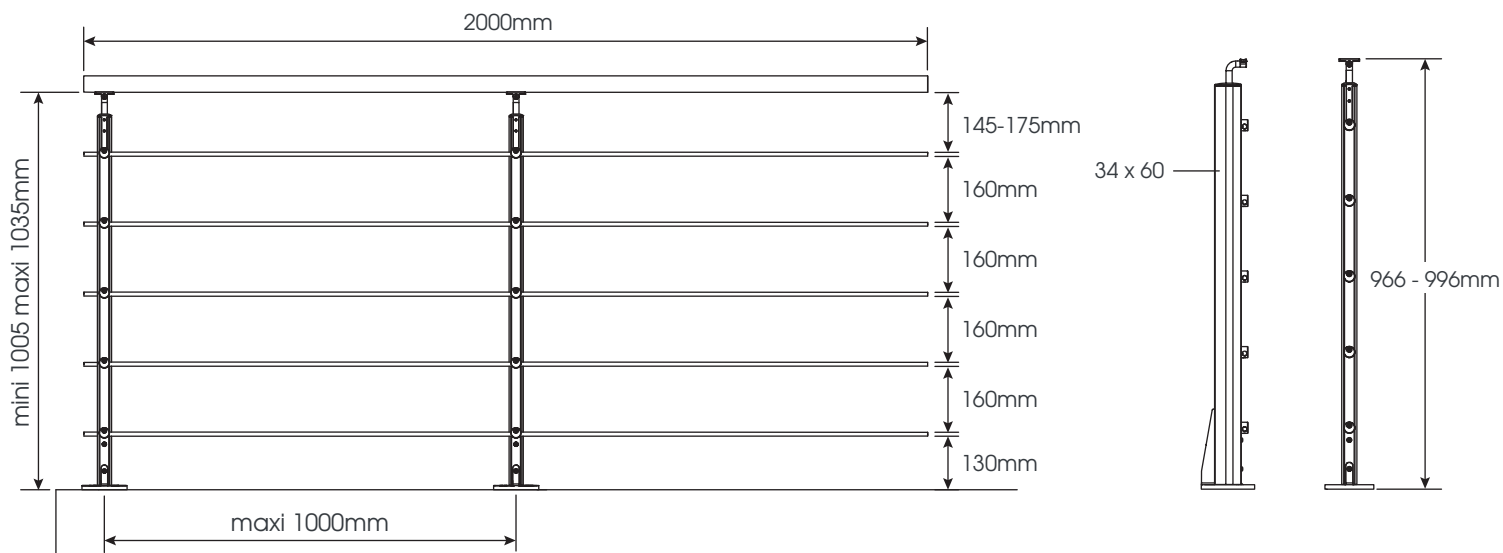

## COMPOSITION

GB Contents of pack • ES Composición • PT Composição • IT Co mposizione • NL Samenstelling • D Zusammensetzung des Bausatzes  
zestawu • RO Piese componente ale kitului • RU Состав набора

• TU kompozisyon • PL Zawartość

1	22017		34x60x895mm	x2
2	22024		Ø40x2000mm	x1
3	70281		Ø10x2000mm	x5

4	72361		x2
5	72361		x2
6	72521		x2
7	72361		x10
8	70638		x5
9	70014		x1
10	70632		x10
11	MEM1		x2

A	72522		M6x70mm	x4
B	72361		Ø5x40mm	x10
C	72361		M6x20mm	x4
D	72411		Ø5x20mm	x4

# Montage du poteau

x2

GB post assembly • ES ensamble del poste • PT montagem do poste • IT assemblaggio del palo • NL assemblage paal  
 • D Zusammenbau des Pfostens • TU direk birleştirici-toplayıcı • PL montaż słupka • RO asamblarea stâlpului • RU Сборка опоры

Сборка

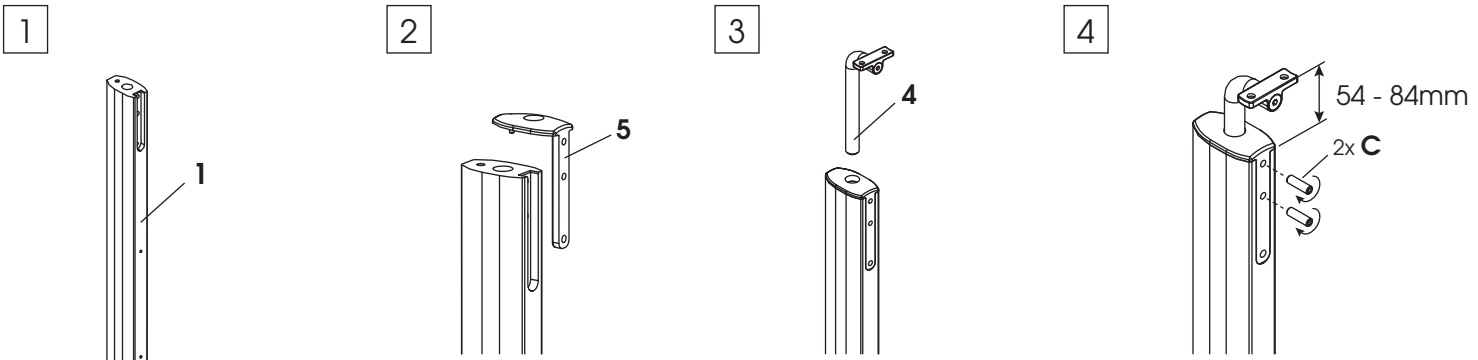

Ne pas serrer trop fort

GB • don't tighten too hard  
 ES • no apretar demasiado fuerte  
 PT • Não apertar muito forte  
 IT • non stringere troppo forte  
 NL • Niet te krachtig vastzetten  
 D • Nicht zu fest anziehen  
 TU • A şırı sıkmayın  
 PL • Nie przekręcaj  
 RO • Nu strângeți  
 RU • Не затягивайте

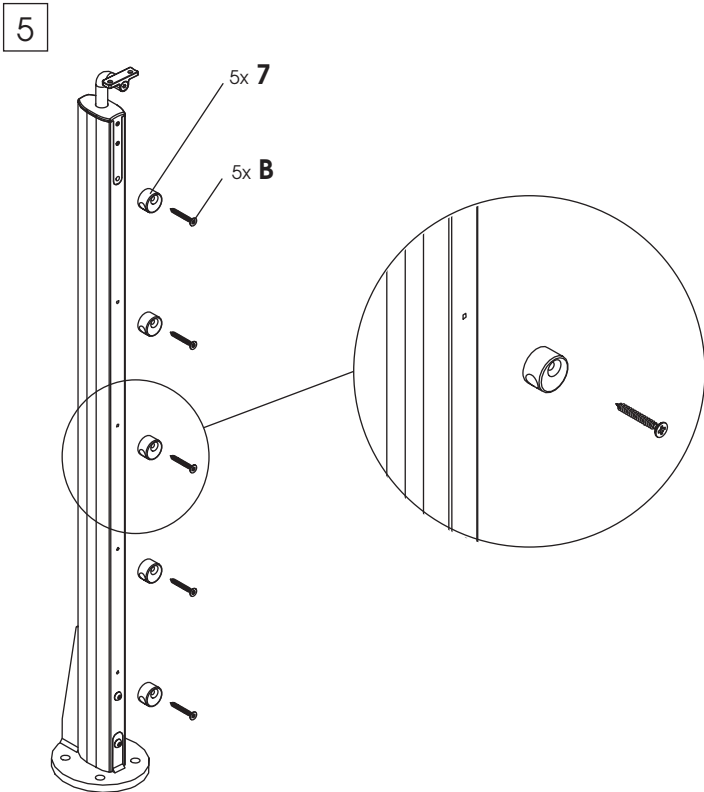
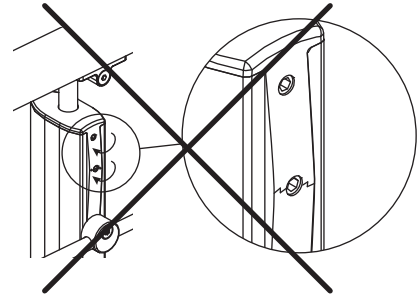

## montée d'escalier

GB • for crawling stairs  
 ES • para el rastreo escaleras  
 PT • para rastreamento de escadas  
 IT • per la scansione scale  
 NL • voor het crawlen trappen  
 D • für Treppenaufgang,  
 TU • merdiven basamakları için  
 PL • do schodów  
 RO • pentru urcarea scărilor  
 RU • для лестницы, несущие балки крепятся горизонтально.

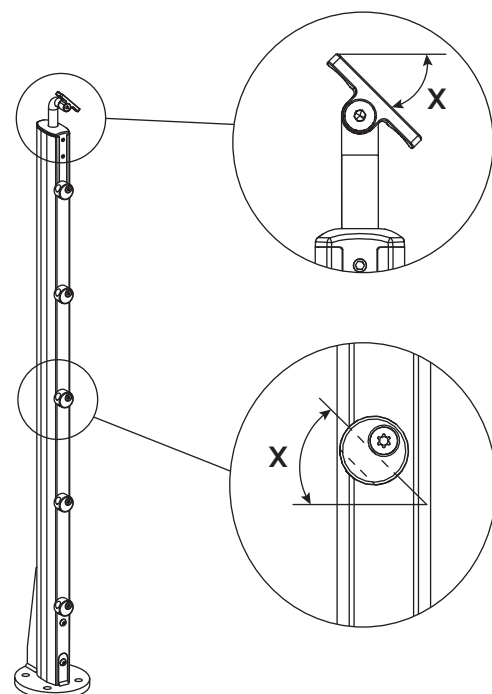
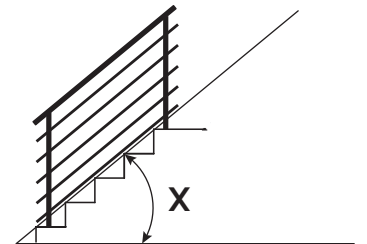

## Fixation au sol

•GB accessories postes fasteners • ES accesorios postes sujetadores • PT acessórios postes prendedores • IT Accessori pali fermi • NL accessoire paal bevestigingsmiddelen • D Zubehör Pfosten Verschlüsse • TU direkleri tutturma aksesuari • PL akcesoria słupki mocuj  
• RO Pieșele componente ale kitului • RU аксессуары столбы крепеж

açe

### F1 tirefonds pour sol bois

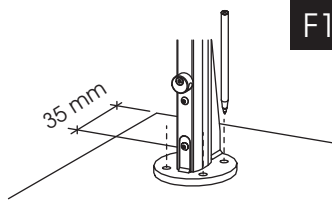

GB • Lag bolts for wood floors  
ES • Tirafondos para suelos de madera  
PT • Tira-fundo para pavimento em madeira  
IT • Tirafondi per pavimento in legno  
NL • Slotschroef voor houten vloer  
D • Sechskantschrauben für Holzboden  
TU • a ғаç zemin için civata  
PL • Wkr ęt do podłogi drewnianej  
RO • Șuruburi autofiletante pentru podea din lemn  
RU • Фундаментальные болты для деревянного пола

### F2 tirefonds pour sol béton

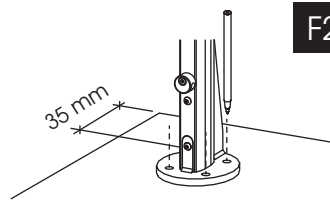

GB • Anchor bolts for concrete floors  
ES • Tacos para suelos de hormigón  
PT • Cavilhas para pavimento em betão  
IT • Caviglie per pavimenti in cemento  
NL • Pluggen voor betonnen vloer  
D • Schwerlastanker für Betonboden  
TU • beton zemin için civata  
PL • Monta ż por ęczy do ściany  
RO • Dibluri pentru podea din beton  
RU • Штыри для бетонного пола.

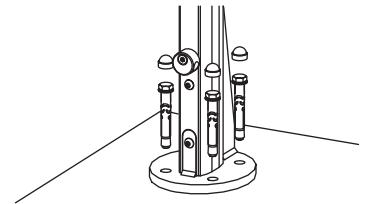
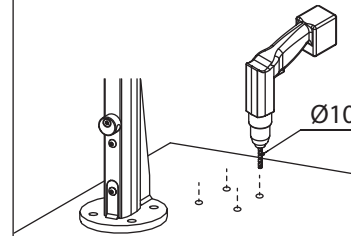
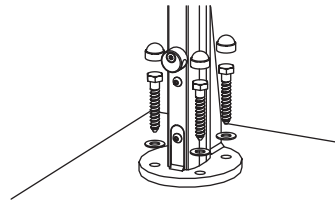
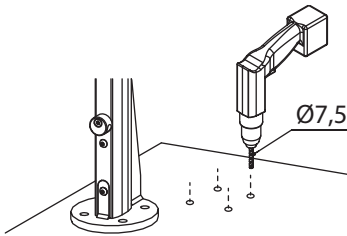

## Fixation des tubes

GB • Tube fastening  
ES • Fijación para tubos  
PT • Fixação para tubos  
IT • Fissaggio per tubi  
NL • Bevestiging voor buizen  
D • Befestigung für Rohre  
TU • Borular için sabitleme  
PL • Zamocowanie przewodów rurowych  
RO • Suport tuburi  
RU • Фиксатор для труб

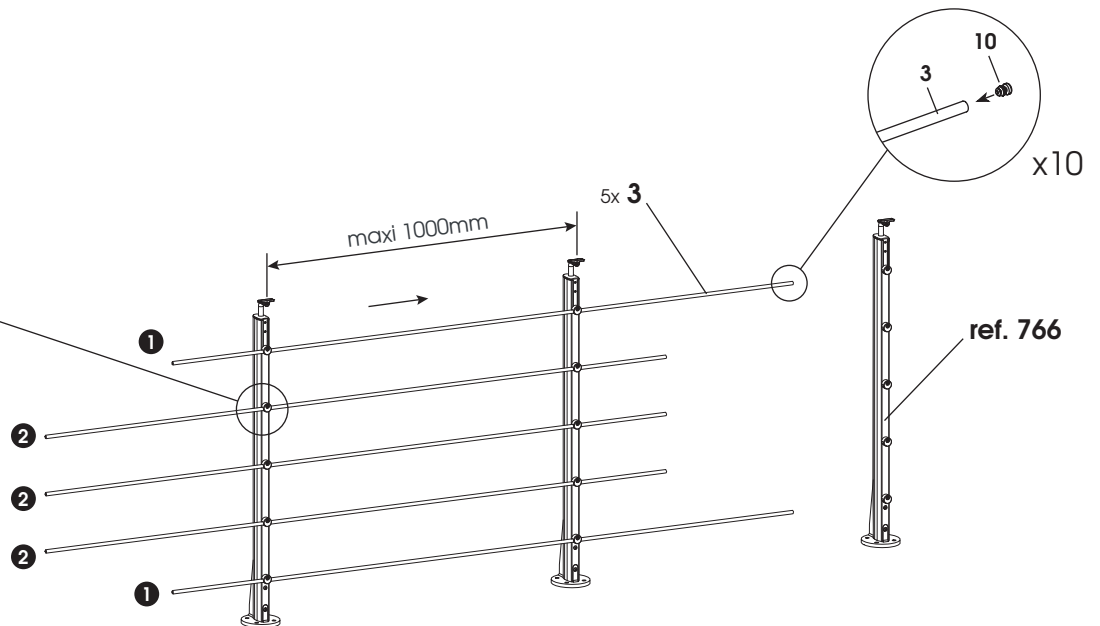
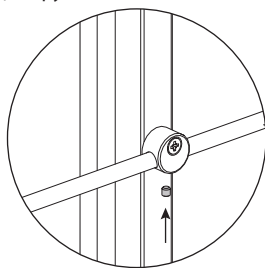

## Fixation de la main courante

GB • Fastening the handrail to the post  
ES • Fijación de pasamanos a la postes  
PT • Fixação de corrimão na postes  
IT • Fissaggio di ringhiera su pali  
NL • Bevestiging van leuning aan paal  
D • Befestigung für Handlauf an der Pfosten  
TU • dire ğe korkulukları tutturma  
PL • Zamocowania por ęczy do słupki  
RO • fixare pol balustrad ă  
RU • Крепление перил к опоры

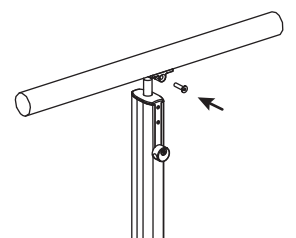
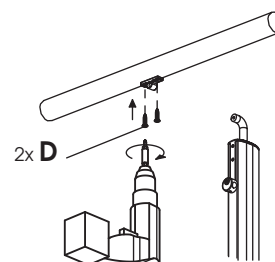
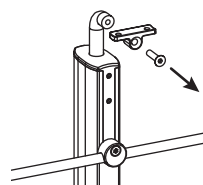
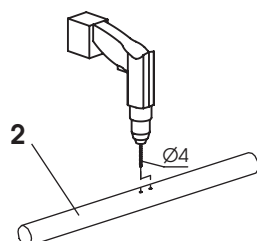
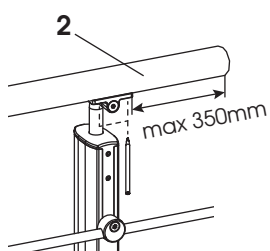
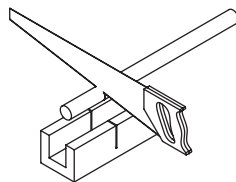

## Assemblage des tubes

x5

GB Assemblers for stainless steel tubes • ES montadores de tubos de acero inoxidable • PT montadores de tubos de aço inoxidável • IT assemblatori di tubi in acciaio inox • NL monteurs voor roestvrij stalen buizen • D Montagebetriebe für Edelstahlrohre • TU Birleştirci Paslanmaz tüb • PL monterzy dla rur ze stali nierdzewnej • RO piese de asamblare inox • RU монтажники для труб из нержавеющей стали

tevi

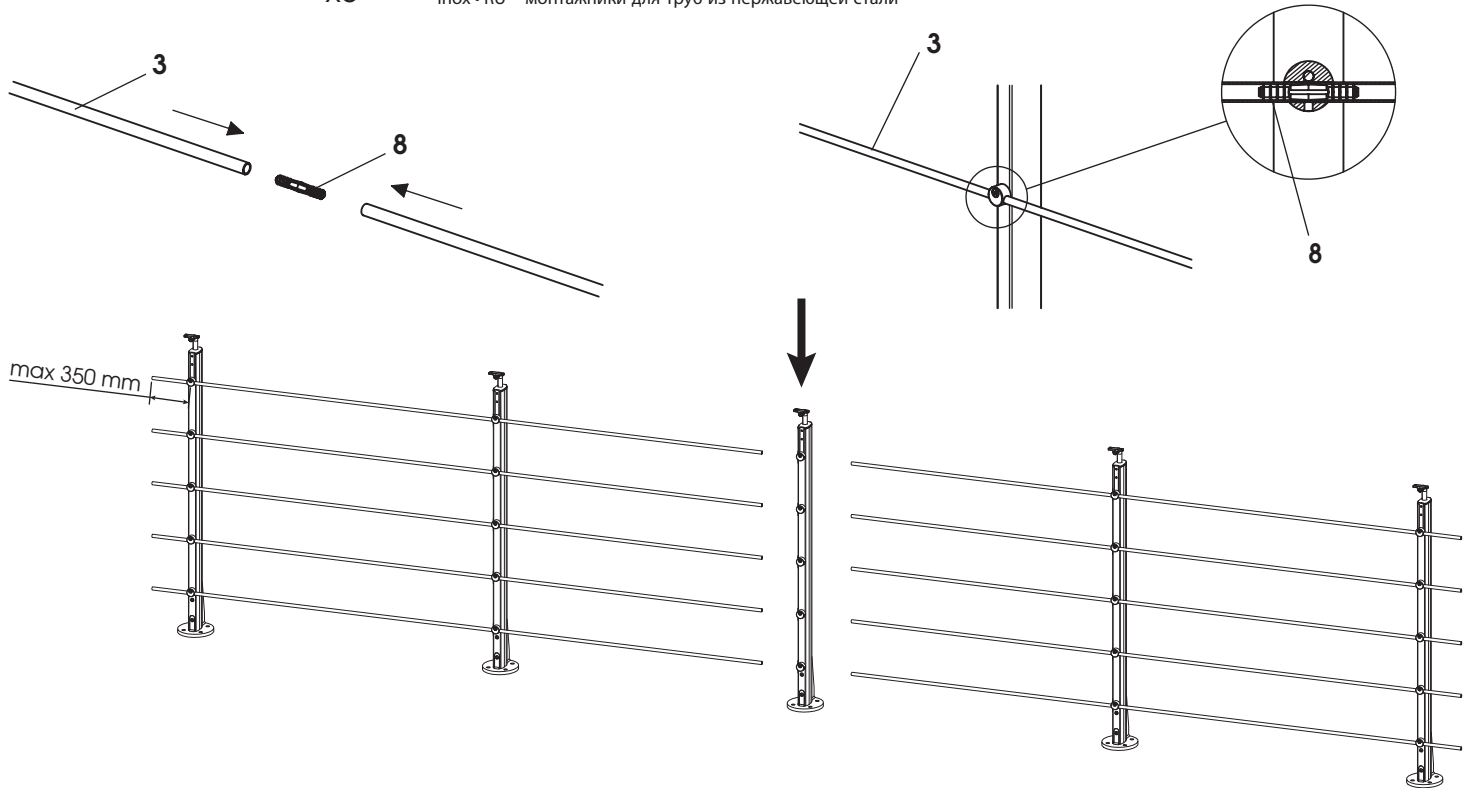

## Assemblage de la main courante

GB Connectors for handrails • ES Ensambladores para pasamanos • PT Mecanismos de montagem para corrimãos • IT Assemblatori per corrimano • NL Montage-elementen voor leuning • D Verbinder für Handläufe • TU korkulukları birleştirci • PL Elementy mocujące do poręczy • RO Conectori pentru mână curentă • RU Муфты под поручни

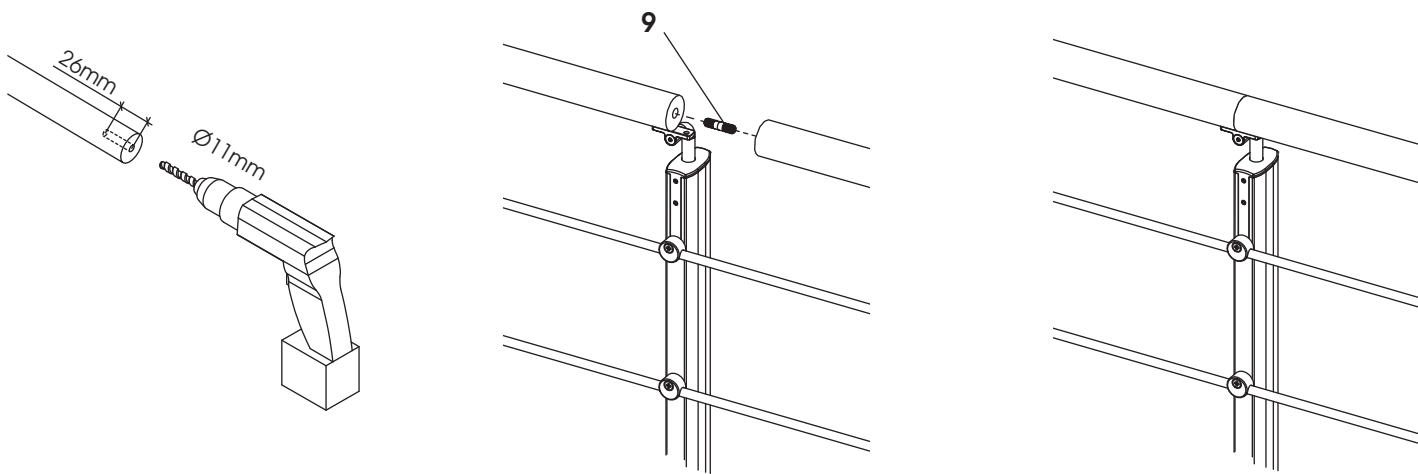

## Finition de la main courante

GB Handrail end caps  
 ES Conteras de acabado de pasamanos  
 PT Tampões de extremidade de corrimão  
 IT Ghiera di finitura del corrimano  
 NL Dopstukken leuning  
 D Endkappe für Handlauf  
 TU Dökme alüminyum korkuluk biti yüksekliği  
 PL Końcówki poręczy  
 RO Capace de finisare pentru mâna curentă  
 RU Наконечники для окончательной отделки поручней.

